

For further information or specifications, visit the technical section of our website www.escea.com to view the latest product Installation Manual.

Appliance Information

Product Dimensions

All dimensions are in mm

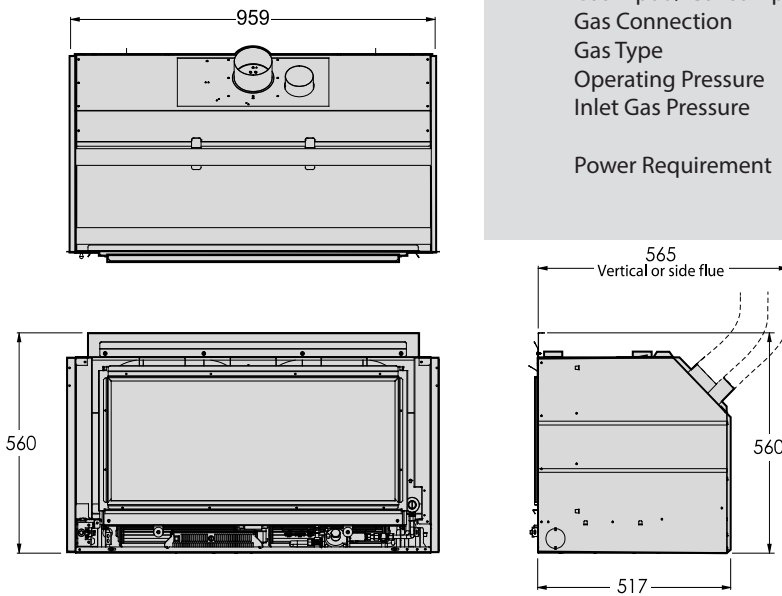

Gas Specifications

Heat Output	9.2kW*
Gas Input / Consumption	38MJ/hr*
Gas Connection	Rear right or front right, 1/2" BSP female thread
Gas Type	Natural Gas / LPG (NZ) / Propane (Aus)
Operating Pressure	1.0kPa NG / 2.3kPa LPG or Propane
Inlet Gas Pressure	1.2kPa to 5.0kPa NG 2.75kPa to 5.0kPa LPG or Propane
Power Requirement	3 pin earthed 230V power outlet to be within 1.0m of rear left hand corner of the appliance

Cavity Construction

Cavity Dimensions

The cavity size is dependant on fascia type as the Rado fascia is recessed into the wall. Where possible, it is recommended that the cavity is made 5-10mm larger than the dimensions shown to give the installer the maximum amount of space to work in.

It is not necessary to line the sides, top or back of the cavity.

The wall directly above the Rado fascia must be constructed with non combustible materials, but all other surrounding walls and cavity materials may be constructed with combustible materials.

The cavity and surrounding walls for Velo or Quadrato fascias may be constructed using combustible materials.

Mantle Clearances

Any combustible mantles or protruding ledges above the fireplace must not extend outside the dimensions shown.

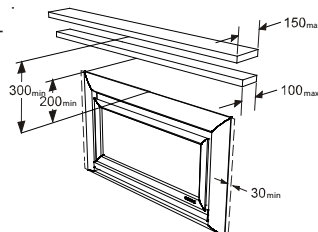

Cavity for Velo, Quadrato or Quadrato Lite Fascia

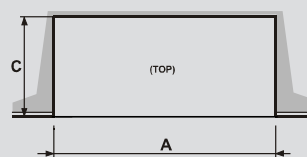
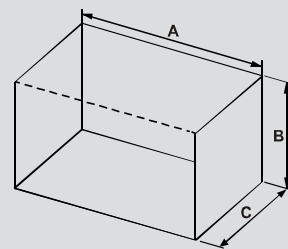

Cavity for Rado Fascia

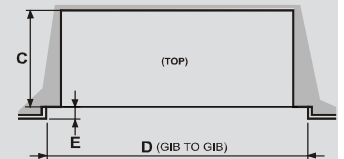
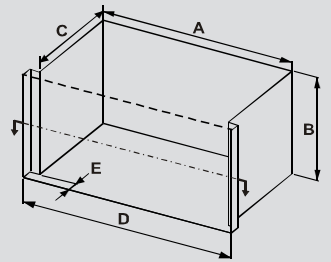

Ideal Cavity Dimensions (mm):

	A	B (min)	B (max)	C	D	E
Velo / Quadrato / Quadrato Lite	960	560	575	565	-	-
Rado	965	583	586	565	995	30 to 130

Horizontal Powerflue Description:

The Horizontal Powerflue Wall Terminal must be weather-tight when installation is complete to prevent damage to the dwelling, and must be installed accordance with AS/NZS 5601 and any other relevant building codes.

The Horizontal Powerflue connects to the appliance via two Ø100mm and Ø75mm flexible flues.

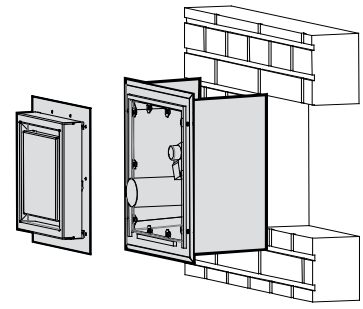

Flue Configurations:

The maximum length of flue is 4m and minimum 600mm, and may be run in any variety or combination of directions or angles as required, providing it does not extend past 1.5m horizontally downwards.

Where possible, the flue terminal should not be situated in areas exposed to high winds and extreme weather.

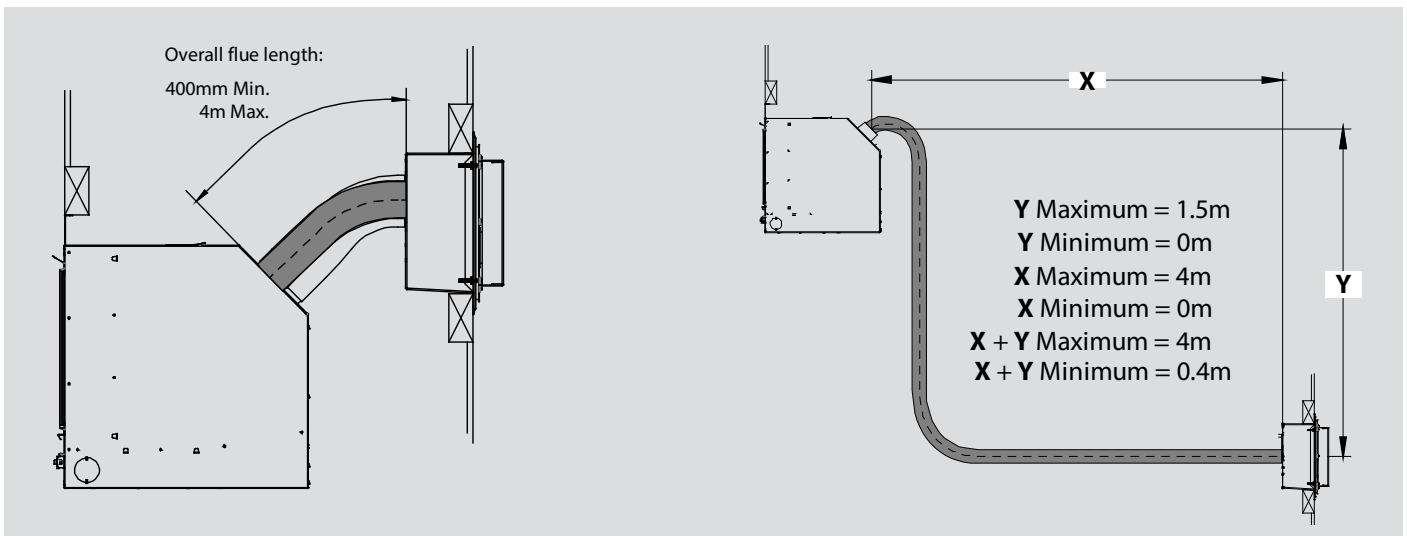

Cavity Size for Horizontal Powerflue:

When cutting the hole in the outside wall, be mindful of how the installation Horizontal Powerflue Wall Terminal will be finished, the installation must be weatherproof.

Ideal hole/cavity size for Horizontal Powerflue

X	298mm
Y	298mm
Z	175mm*

* Note, Z dimension does not include allowance for flue which exists here as shown in the above diagrams. If the flue is exiting the powerflue and immediately going downwards, Z dimension will need to be at least 400mm to allow for the flue and flue bend radius.

